

ANSYS SpaceClaim Direct Modeler

3-D for Innovative Simulation

In today's business world, company resources are being stretched increasingly thinner; there are fewer people available to handle larger workloads, schedules are tighter and budgets are smaller. The need to cost-effectively shorten product design cycles and remove impediments to the product development process is stronger than ever.

ANSYS® SpaceClaim Direct Modeler™ software brings 3-D solid modeling to the desktops of analysts who work in a 3-D world but do not want to become experts in traditional, feature-based CAD systems. It enables product development and design engineers who are not CAD proficient to create and modify 3-D geometry models. As a result, simulation can be conducted earlier in the product development process, where it can have the most impact on performance and cost.

ANSYS SpaceClaim Direct Modeler software helps analysts interact with CAD geometry in exciting new ways. Users can easily make dramatic changes to existing models or conceptualize on the fly, and experiment with many design variations — all in a fraction of the time it would take using traditional methods.

Direct modeling revolutionizes the way engineers think about working with 3-D solid models, enabling them to focus on designing rather than working around the constraints of their parametric CAD tool. Unlike traditional, feature-based CAD, ANSYS SpaceClaim Direct Modeler software allows users to reuse data and easily incorporate geometry from other designs, even those created in CAD systems. A design can be changed however the analyst sees fit, regardless of how it was built or the CAD system in which it was created.

Intuitive tools such as Pull and Move let users directly select portions of the model and move them wherever they want. The Combine tool slices and divides parts into pieces so that portions from other designs can be merged in. The Fill tool cleans up small features and fills holes. Together, these direct-modeling tools empower users to complete jobs without resorting to traditional CAD.

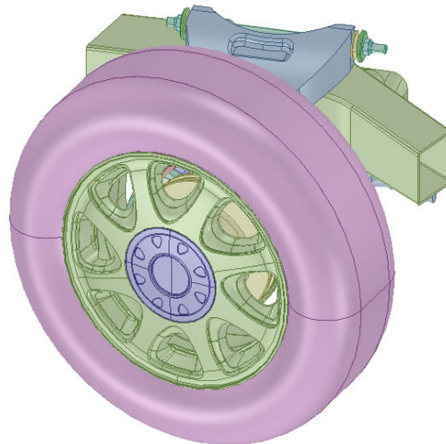

ANSYS SpaceClaim Direct Modeler software interoperates with all major native CAD and neutral file formats

Product Features

Industry-Leading Direct Modeling

- Scale from simple shapes to complex blends and variable section sweeps
- Pull and Move tools work on both faces and edges
- Add hints for thin walls, mirrored, concentric, rounded and chamfered geometry

Powerful, Straightforward 3-D

- Access Pull, Move, Fill and Combine tools that enable hands-on 3-D design
- Quickly create and iterate design concepts
- Create solid models without the complexity of traditional, feature based CAD

3-D Cross-Section Creation and Manipulation

- Draw 3-D extruded, revolved and swept geometry without leaving a 2-D cross section
- Efficiently sketch out new concepts for 3-D designs
- Import complex assembly, section through it, and edit using Pull and Move tools

Parameters without Constraints

- To change dimension values, select what to move and edit the value
- No need to set up complicated systems of constraints
- Set up, save and share sets of dimensions

Flexible Assembly Structure

- Turn a part into an assembly or vice versa
- Create an assembly structure before the shape is drawn
- Draw many parts and create the structure later
- Inter-component relationships do not prevent changes
- Export subassemblies into external files for reuse in other simulations
- Incorporate existing designs for customization

Design in Any Context

- Use the same tools to edit assemblies, parts and drawing views
- Communicate changes with 3-D markups
- No need to worry about switching to the right mode

Generate Mid-Surface Geometry

- Turn 3-D solid models into mid-surface models for shell meshing and analysis
- Extend and resolve complex 3-D intersections with direct modeling tools

System Requirements

Operating Systems: Microsoft® Windows® XP with Service Pack 2; Microsoft Windows Vista; Microsoft Windows 7

Video Card: requires full DirectX 9c, February 2007 edition or greater; hardware support for 64MB of graphics memory or higher; Shader 3.0 hardware support at 32 bits per pixel, 1024x768 minimum resolution; latest graphics driver

CPU: Pentium® 4 2.0GHz or Athlon™ 2000+ or faster, 32-bit (x86) or 64-bit (x64) processor

RAM: minimum 512MB RAM (32-bit); 1Gb RAM (64-bit)

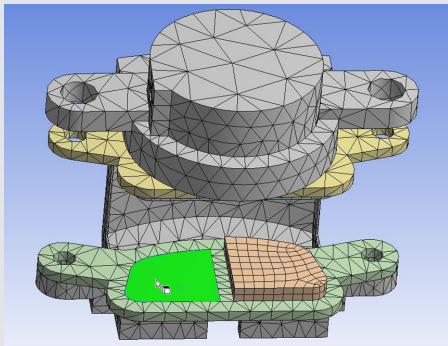

The transfer of shared topology from ANSYS SpaceClaim Direct Modeler software to the ANSYS Workbench platform is shown in this brake caliper assembly

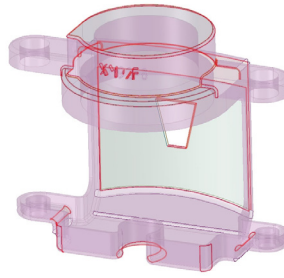

ANSYS SpaceClaim Direct Modeler software automatically finds and fixes problematic areas, creating clean geometry for meshing and analysis.

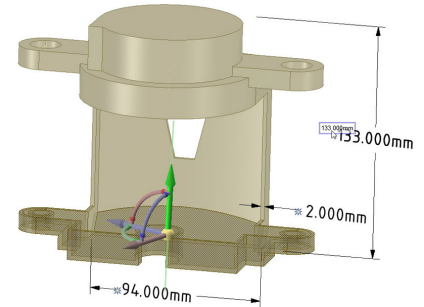

Building dimensional intelligence into dumb models for parametric studies within the ANSYS Workbench environment

Fastest, Most Innovative 3-D Direct Modeler

ANSYS SpaceClaim Direct Modeler software enables engineers to easily create concepts and prepare existing designs for analysis and simulation. The product fully interoperates with ANSYS® 13.0, 12.0 and 11.0 software as well as the ANSYS® Workbench™ platform, allowing users to:

- Rapidly create new concepts as simple as sketching them on paper; start with a blank screen and produce a concept model ready for simulation
- Import an existing CAD model designed for manufacture and prepare it for simulation; remove small surfaces, fillets and unnecessary details
- Load a non-parametric model, such as IGES, Parasolid®, etc., and manipulate it as if it were fully parametric
- Virtually test operational performance within the ANSYS Workbench simulation environment

Beam modeling capabilities:

- Import solid geometry from CAD and convert it to beam elements
- Recognize and group matching cross-sections during extraction
- Automatically extend beams to meet each other
- Sketch new beams using 3-D sketching or by lofting between points using the Pull tool
- Edit beam models with ANSYS SpaceClaim Direct Modeler's Pull, Move, and Fill tools
- Use the Move tool to offset a beam location while keeping the cross-section fixed
- Define new cross sections and add them to your beam library
- Create associative truss structures by defining beams at the intersection of solids and planes.
- ANSYS can optimize the size of the structure and beam sections

ANSYS[®]
ansys.com

ANSYS, Inc.
Southpointe
275 Technology Drive
Canonsburg, PA 15317
U.S.A.
724.746.3304
ansysinfo@ansys.com

Toll Free U.S.A./Canada:
1.866.267.9724
Toll Free Mexico:
001.866.267.9724
Europe:
44.870.010.4456
eu.sales@ansys.com



GSA Contract Holder

ANSYS, ANSYS Workbench, HP55, AUTODYN, CFX, FLUENT and any and all ANSYS, Inc. brand, product, service and feature names, logos and slogans are registered trademarks or trademarks of ANSYS, Inc. or its subsidiaries in the United States or other countries. ICEM CFD is a trademark used under license. All other brand, product, service and feature names or trademarks are the property of their respective owners.